



Investor Presentation – November 2021

TSX: PPTA

NASDAQ: PPTA

Perpetua Resources

Responsible Mining.

Critical Resources.

Clean Future.



FORWARD LOOKING STATEMENTS

Information and statement contained in this presentation that are not historical facts are “forward-looking information” or “forward-looking statements” (collectively, “Forward-Looking Information”) within the meaning of applicable Canadian securities legislation and the United States Private Securities Litigation Reform Act of 1995. Forward Looking Information includes, but is not limited to, information concerning the Company’s business including but not limited to statements with respect to results of the FS (as defined below); disclosure regarding possible events, conditions or financial performance that is based on assumptions about future economic conditions and courses of action; the timing and impact of future activities on the Project, including but not limited to the ability to address legacy features left by previous operators; the anticipated economic, environmental and other benefits of the Project; the viability of the Project; development and operating costs in the event that a production decision is made; success of exploration, development and environmental protection, closure and remediation activities; permitting time lines and requirements; requirements for additional capital; requirements for additional water rights and the potential effect of proposed notices of environmental conditions relating to mineral claims; risks and opportunities associated with the Project; planned exploration and development of properties and the results thereof; planned expenditures, production schedules and budgets and the execution thereof. Statements concerning mineral resource and mineral reserve estimates may also constitute Forward-Looking Information to the extent that they involve estimates of the mineralization that may be encountered if the Stibnite Gold Project is developed. In preparing the Forward-Looking Information herein, the Company has applied several material assumptions, including, but not limited to, that any additional financing needed will be available on reasonable terms; the exchange rates for the U.S. and Canadian currencies will be consistent with the Company’s expectations; that the current exploration, development, environmental and other objectives concerning the Stibnite Gold Project can be achieved and that its other corporate activities will proceed as expected; that the current price and demand for gold and antimony will be sustained or will improve; that general business and economic conditions will not change in a materially adverse manner and that all necessary governmental approvals for planned activities on the Stibnite Gold Project will be obtained in a timely manner and on acceptable terms; the continuity of the price of gold and other metals, economic and political conditions and operations; that the circumstances surrounding the COVID-19 pandemic, although evolving, will stabilize or at least not worsen; and the assumptions set out in the FS. Forward-Looking Information involves known and unknown risks, uncertainties and other factors which may cause the actual results, performance or achievements of the Company to be materially different from any future results, performance or achievements expressed or implied by the Forward-Looking Information. Such risks and other factors include, among others, the industry-wide risks and project-specific risks identified in the FS; risks related to the availability of financing; operations and contractual obligations; changes in exploration programs based upon results of exploration; changes in estimated mineral reserves or mineral resources; future prices of metals and minerals; availability of personnel and equipment equipment; equipment failure; accidents, effects of weather and other natural phenomena and other risks associated with the mineral exploration industry; environmental risks, including environmental matters under US federal and Idaho rules and regulations; impact of environmental remediation requirements and the terms of existing and potential consent decrees on the Company’s planned exploration and development activities on the Project; certainty of mineral title; community relations; delays in obtaining governmental approvals or financing; the Company’s dependence on one mineral project; the nature of mineral exploration and mining and the uncertain commercial viability; the Company’s lack of operating revenues; governmental regulations and the ability to obtain necessary licenses and permits; risks related to prior unregistered agreements, transfers or claims and other defects in title to mineral projects; currency fluctuations; changes in environmental laws and regulations and changes in the application of standards pursuant to existing laws and regulations; risks related to dependence on key personnel; COVID-19 risks to employee health and safety and a slowdown or temporary suspension of operations in geographic locations impacted by an outbreak; and estimates used in budgeting and financial statements proving to be incorrect; as well as those factors discussed in the Company’s public disclosure record. Although the Company has attempted to identify important factors that could affect the Company and may cause actual actions, events or results to differ materially from those described in Forward-Looking Information, there may be other factors that cause actions, events or results not to be as anticipated, estimated or intended. There can be no assurance that Forward-Looking Information will prove to be accurate, as actual results and future events could differ materially from those anticipated in such statements. Accordingly, readers should not place undue reliance on Forward-Looking Information. Except as required by law, the Company expressly disclaims any obligation to update the Forward-Looking Information herein.

Cautionary Note and Technical Disclosure

The presentation has been prepared by Perpetua Resources management and does not represent a recommendation to buy or sell these securities. Investors should always consult their investment advisors prior to making any investment decisions. All references to “dollars” or “\$” shall mean United States dollars unless otherwise specified.

The material scientific and technical information in respect of the Stibnite Gold Project in this presentation, unless otherwise indicated, is based upon information contained in the technical report titled “Stibnite Gold Project, Feasibility Study Technical Report, Valley County, Idaho” dated effective December 22, 2020 and issued January 27, 2021 (the “FS” or “2020 Feasibility Study”). Readers are encouraged to read the FS, which is available under the Company’s profile on SEDAR, for detailed information concerning the Project. See also “Regulatory Information” at the end of this presentation.

Cautionary Note to U.S. Investors

This presentation includes Mineral Reserves and Mineral Resources classification terms that comply with reporting standards in Canada and the Mineral Reserves and the Mineral Resources estimates are made in accordance with National Instrument 43-101 – Standards of Disclosure for Mineral Projects (“NI 43-101”). NI 43-101 is a rule developed by the Canadian Securities Administrators that establishes standards for all public disclosure an issuer makes of scientific and technical information concerning mineral projects. These standards differ significantly from the requirements of the SEC set the SEC’s rules that are applicable to domestic United States reporting companies. Consequently, Mineral Reserves and Mineral Resources information included in this presentation is not comparable to similar information that would generally be disclosed by domestic U.S. reporting companies subject to the reporting and disclosure requirements of the SEC. Accordingly, information concerning mineral deposits set forth herein may not be comparable with information made public by companies that report in accordance with U.S. standards.



WHY PERPETUA RESOURCES?

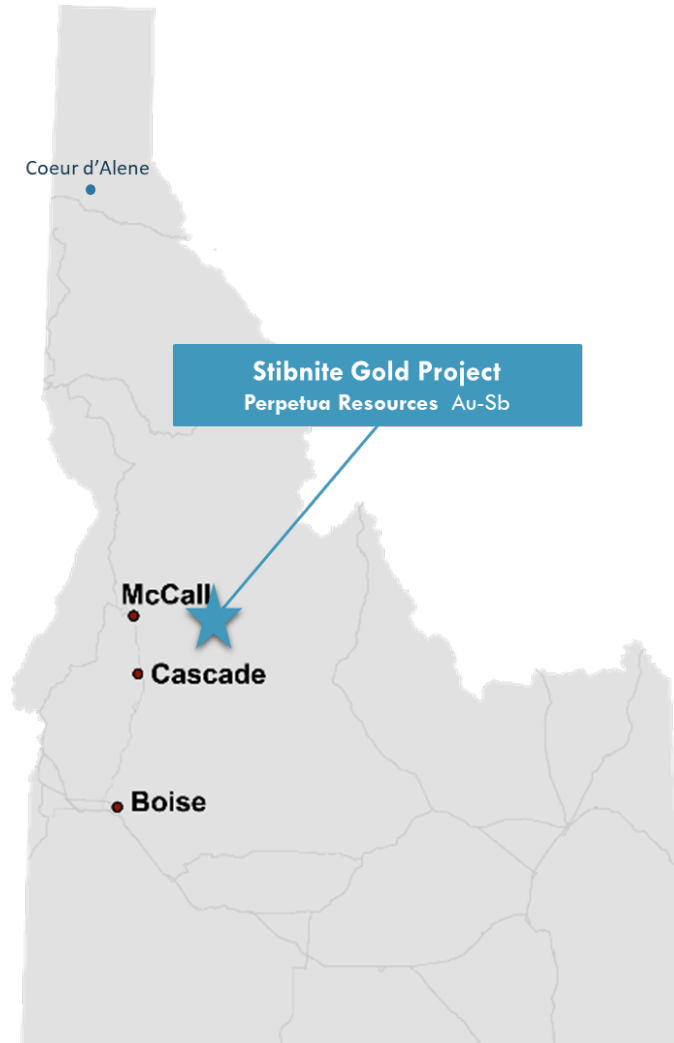

- ✓ Redeveloping one of **largest, highest grade** and **lowest cost** gold projects in the U.S.*
- ✓ **Superior project economics** with ~15 year reserve life and <3 year payback period*
- ✓ Providing a **U.S critical mineral** to power batteries enabling the **low-carbon energy transition** and for national security
- ✓ Located in **stable mining jurisdiction** with **Idaho community** and **political support**
- ✓ **Sustainable approach** to restoring the environment, improving a legacy, and creating value for all stakeholders
- ✓ **Attractive valuation** with **significant near-term catalysts** and strong balance sheet

**Based on the 2020 Feasibility Study (FS) which is intended to be read as a whole and sections should not be read or relied upon out of context. The information in this presentation is subject to the assumptions, exclusions and qualifications contained in the FS. See "Regulatory Information" at the end of this presentation.*



THE STIBNITE GOLD PROJECT

We can take an area abandoned after 100 years of mining activity and use a sustainable approach to restore the environment and develop a modern mining project helping power a lower carbon future through critical mineral production.

ONE OF THE LARGEST^{1,2} GOLD RESERVES IN THE U.S.

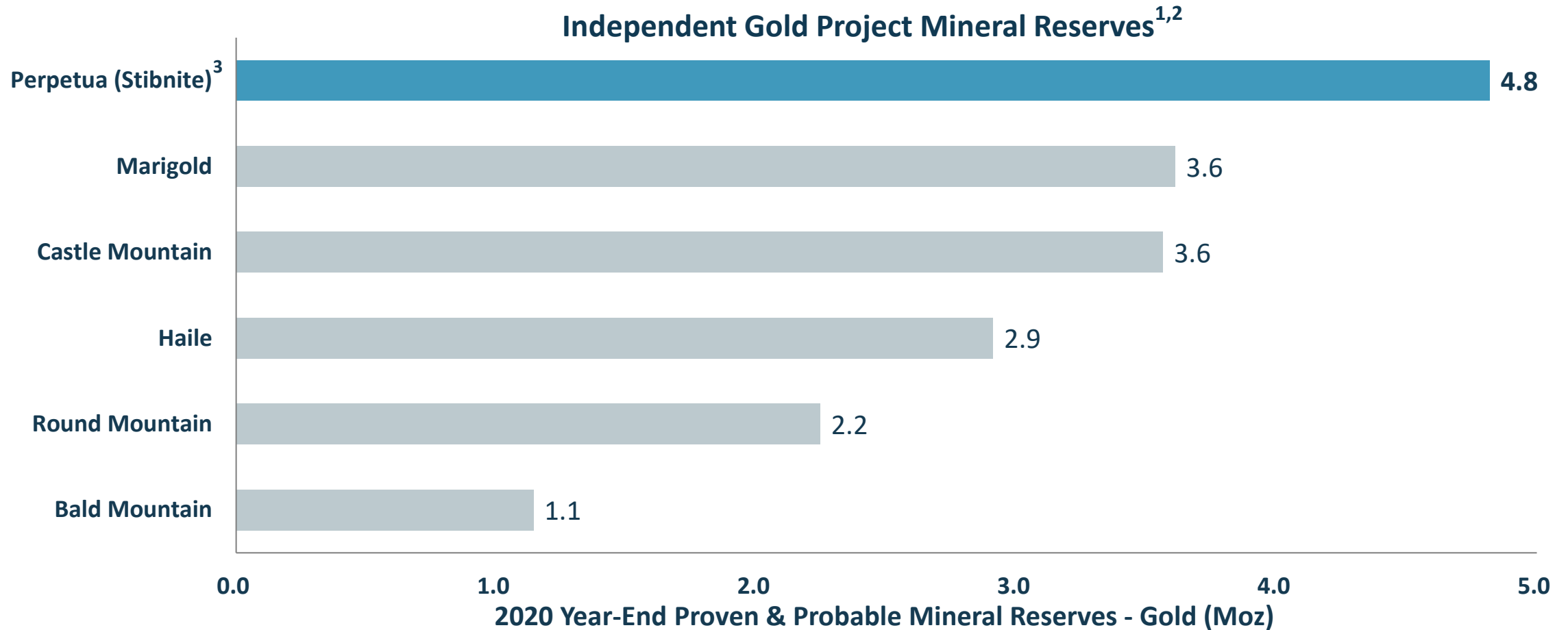

Source: S&P Global – Market Intelligence

1. Excludes Hycroft due to technical uncertainty regarding recoverability of mineral reserves

2. Independent refers to gold projects as not owned by Barrick or Newmont; Independent projects shown are from the lower 48 states in U.S.

3. Based on the 2020 Feasibility Study (FS) which is intended to be read as a whole and sections should not be read or relied upon out of context. The information in this presentation is subject to the assumptions, exclusions and qualifications contained in the FS. See "Regulatory Information" at the end of this presentation.



HIGH-GRADE, OPEN PIT GOLD DEPOSIT

Independent Open Pit Gold Deposits¹

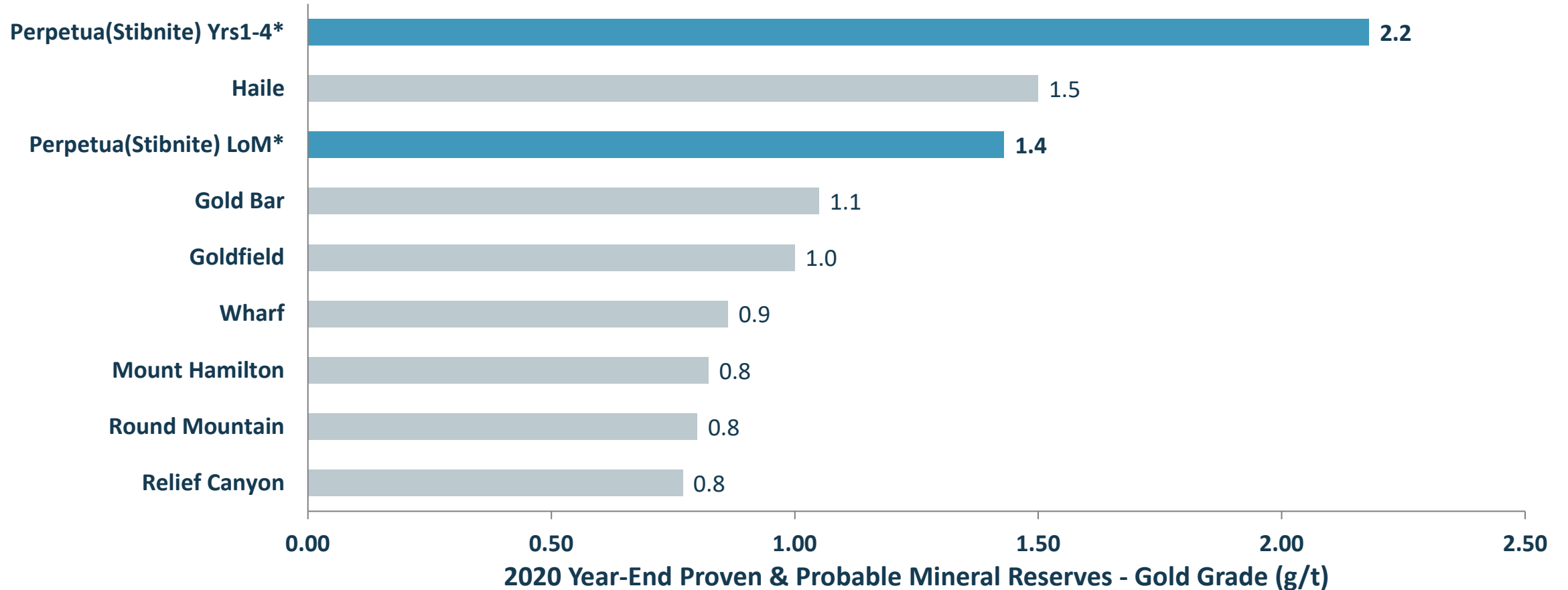

Source: S&P Global – Market Intelligence

1. Independent refers to gold projects as not owned by Barrick or Newmont; Independent projects shown are from the lower 48 states in U.S.

*Based on the 2020 Feasibility Study (FS) which is intended to be read as a whole and sections should not be read or relied upon out of context. The information in this presentation is subject to the assumptions, exclusions and qualifications contained in the FS. See "Regulatory Information" at the end of this presentation.



POISED TO BE ONE OF LARGEST U.S. GOLD MINES

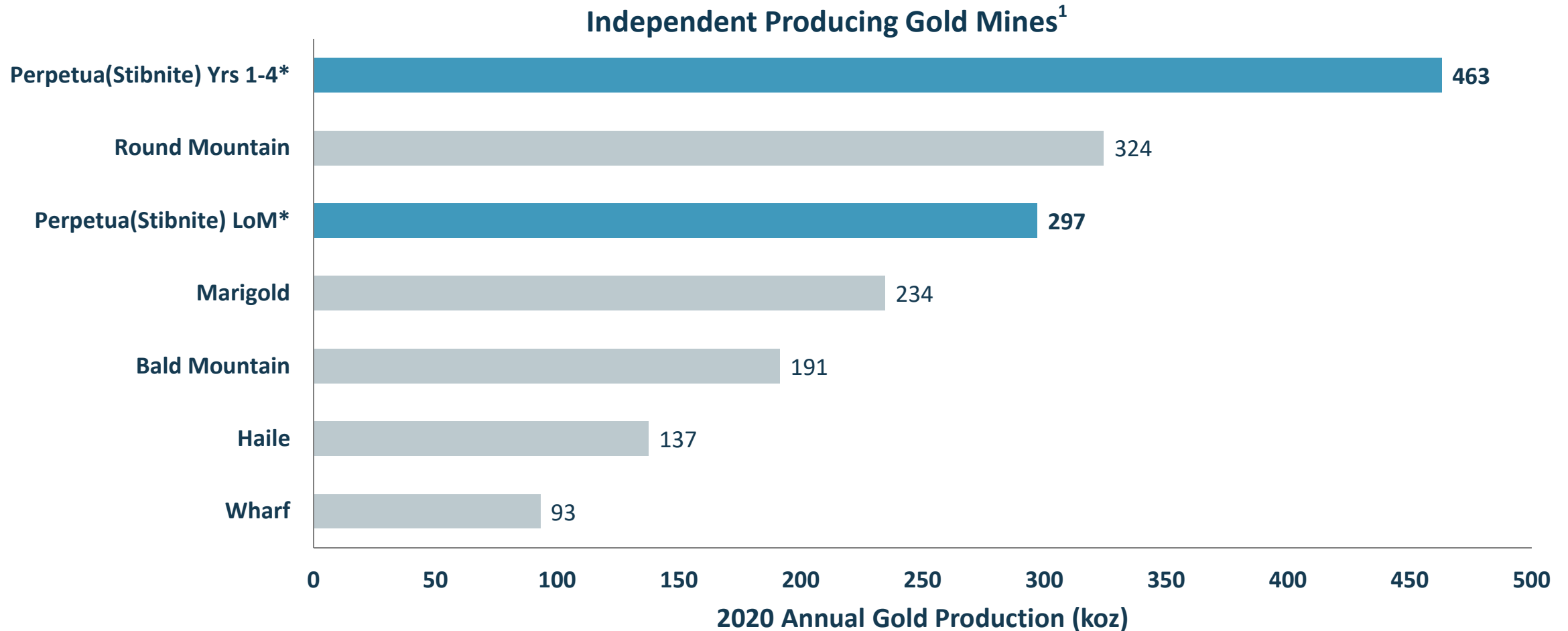

Source: S&P Global – Market Intelligence

1. Independent refers to gold projects as not owned by Barrick or Newmont; Independent projects shown are from the lower 48 states in U.S.

*Based on the 2020 Feasibility Study (FS) which is intended to be read as a whole and sections should not be read or relied upon out of context. The information in this presentation is subject to the assumptions, exclusions and qualifications contained in the FS. See "Regulatory Information" at the end of this presentation.



LOWEST QUARTILE ALL-IN-SUSTAINING COSTS¹

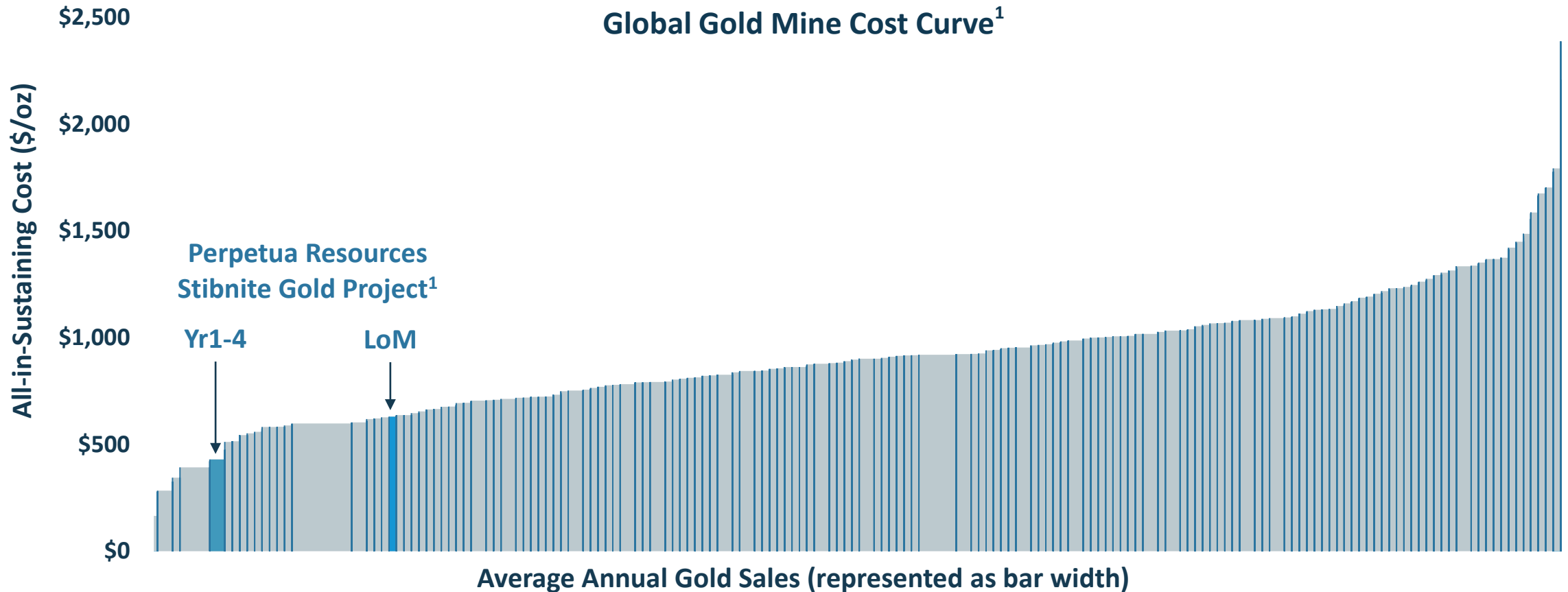

Source: S&P Global – Market Intelligence

Valuable antimony by-product credit of \$70/oz over life of mine¹

1. Based on the 2020 Feasibility Study (FS) which is intended to be read as a whole and sections should not be read or relied upon out of context. The information in this presentation is subject to the assumptions, exclusions and qualifications contained in the FS. See "Regulatory Information" at the end of this presentation. Antimony by-product credit is calculated using antimony price of \$3.50/lb.



SIGNIFICANT LEVERAGE TO HIGHER GOLD PRICES

TRADING AT DEEP DISCOUNT TO PROJECT NET PRESENT VALUE¹

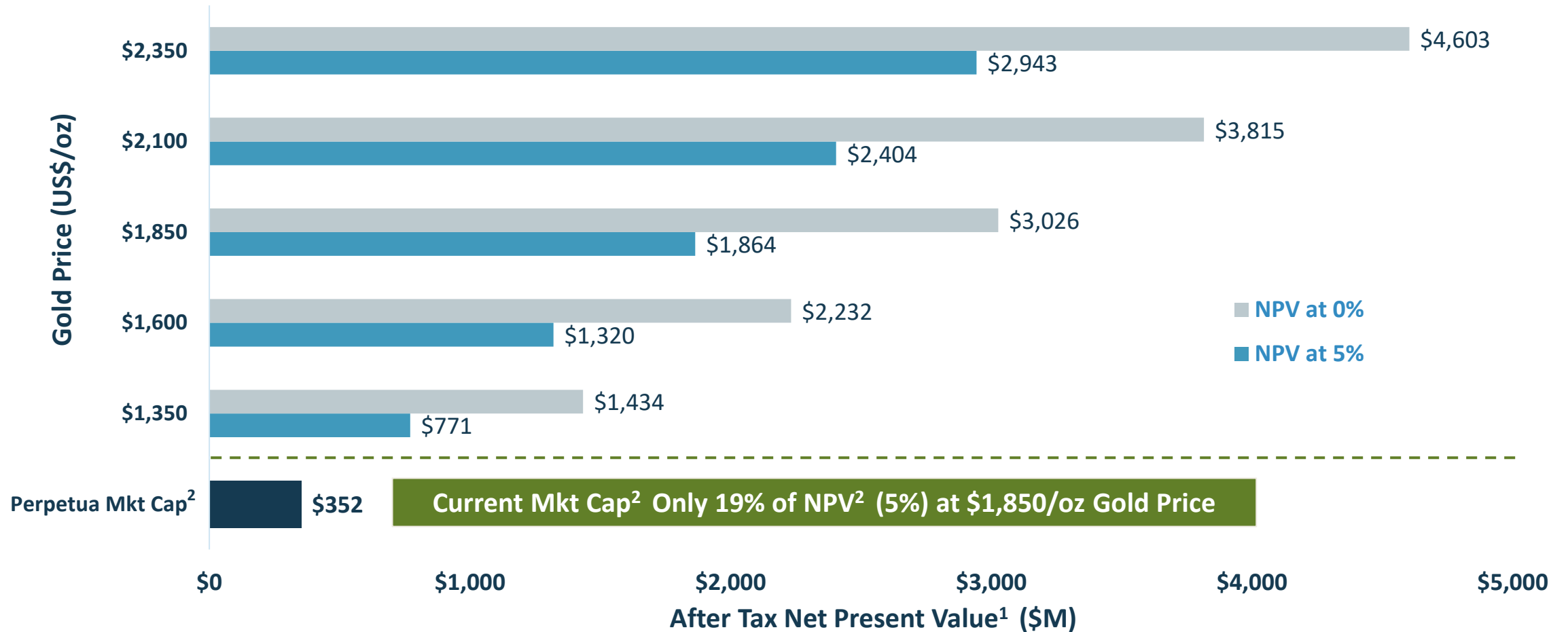

1. Based on the 2020 Feasibility Study (FS) which is intended to be read as a whole and sections should not be read or relied upon out of context. The information in this presentation is subject to the assumptions, exclusions and qualifications contained in the FS. See "Regulatory Information" at the end of this presentation.

2. Perpetua Resources Market Cap based on Fully Diluted Market Cap using closing price as of November 22, 2021 (US\$5.36)



U.S. CRITICAL MINERALS SUPPLY CHAIN RISK

USES FOR ANTIMONY

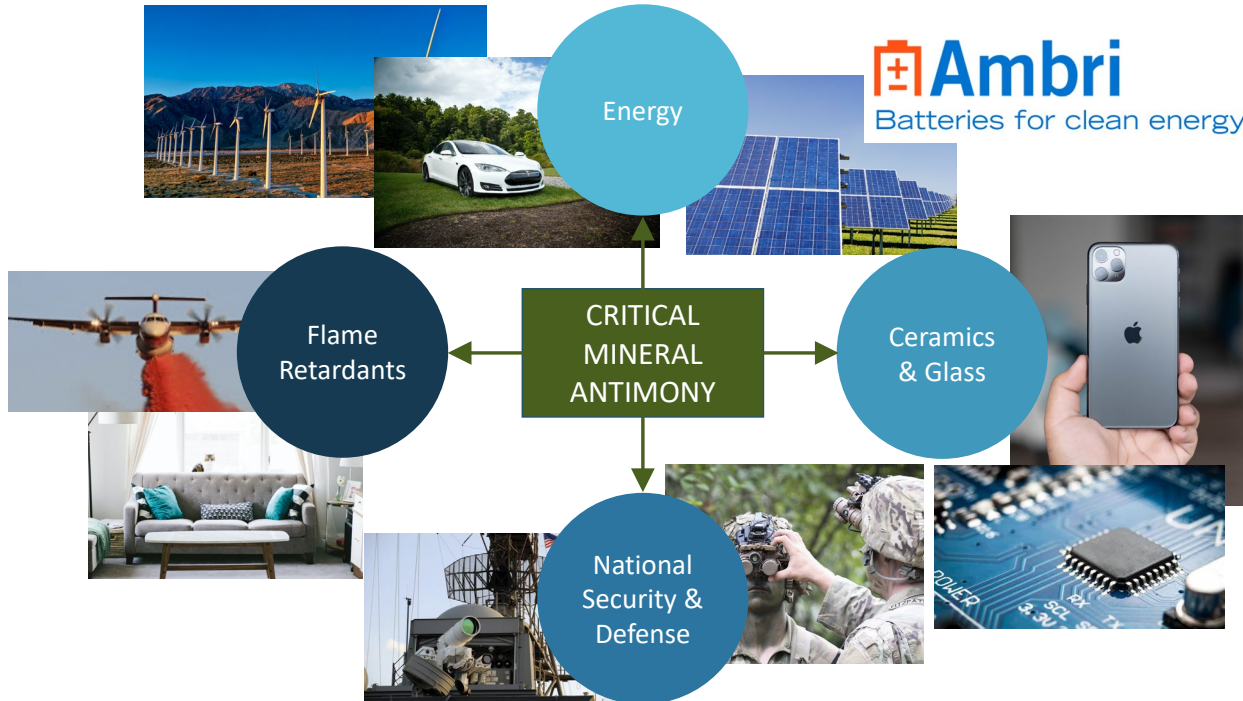

“Critical Minerals” are metals and non-metals essential to economic and national security and are vulnerable to supply chain disruptions

- Antimony is one of 35 federally listed critical minerals
- China & Russia dominate the world antimony supply (>70%)
- U.S. has no domestic antimony production
- Perpetua Resources could re-establish domestic antimony production and protect America’s future

World Antimony 2020 Production (USGS)

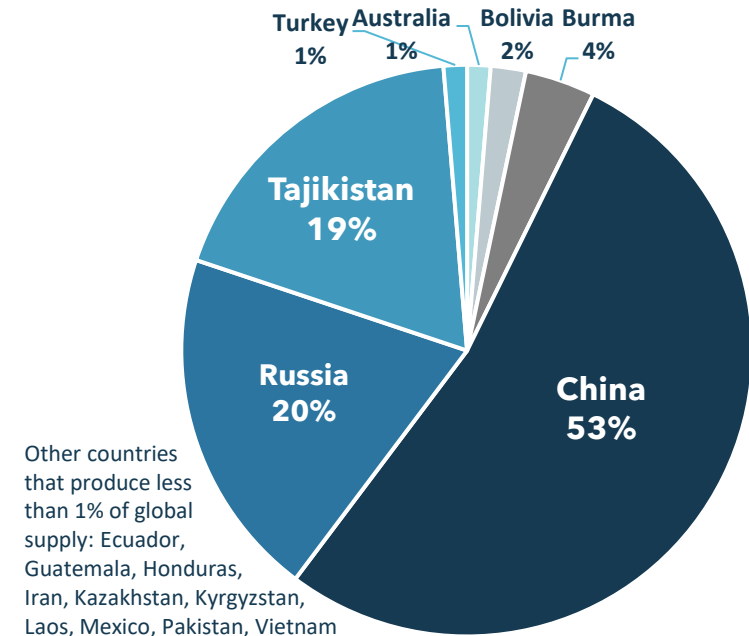



EXPECTED TO AVERAGE >35% OF U.S. DEMAND¹

Stibnite Gold Project Recovered Antimony²

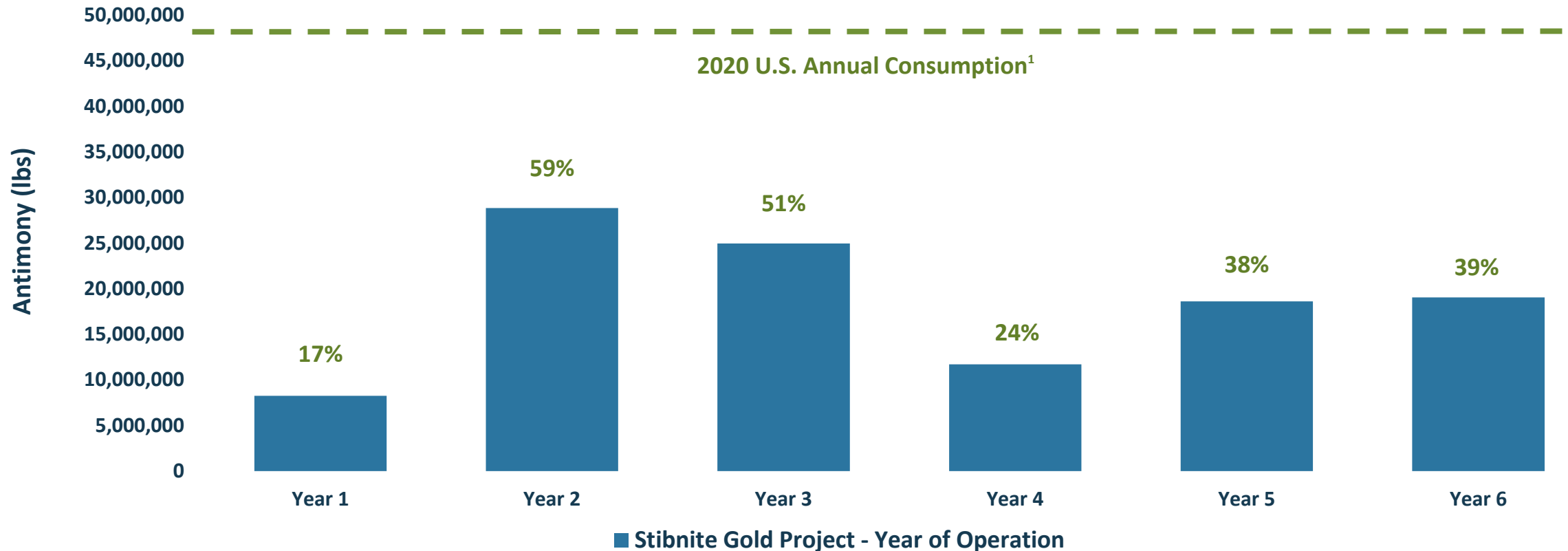

Perpetua Resources would re-establish domestic antimony production, protecting America's future

1. Source: 2021 USGS Antimony commodity summary; all numbers are approximate and may not add due to rounding
2. Based on the 2020 Feasibility Study (FS) which is intended to be read as a whole and sections should not be read or relied upon out of context. The information in this presentation is subject to the assumptions, exclusions and qualifications contained in the FS. See "Regulatory Information" at the end of this presentation.



PERPETUA TO POWER AMBRI'S LOW-COST BATTERY

Agreement to supply only responsible & domestically mined source of antimony for stationary, long duration, daily cycle energy storage enabling the transition to carbon-free power grids

- Current commitment of Perpetua's antimony can power over 13 GWh of energy storage or >8x the total additions to entire U.S. energy storage market in 2020
- Agreement based on standard commercial terms with provisions for fixed pricing and higher volumes as mutually agreed
- Partnering to identify opportunities to reduce carbon emissions in operations through renewable energy combined with battery storage
- Ambri recently secured \$144M from Reliance Industries, Paulson & Co., Bill Gates and others to accelerate growth and build a domestic manufacturing facility

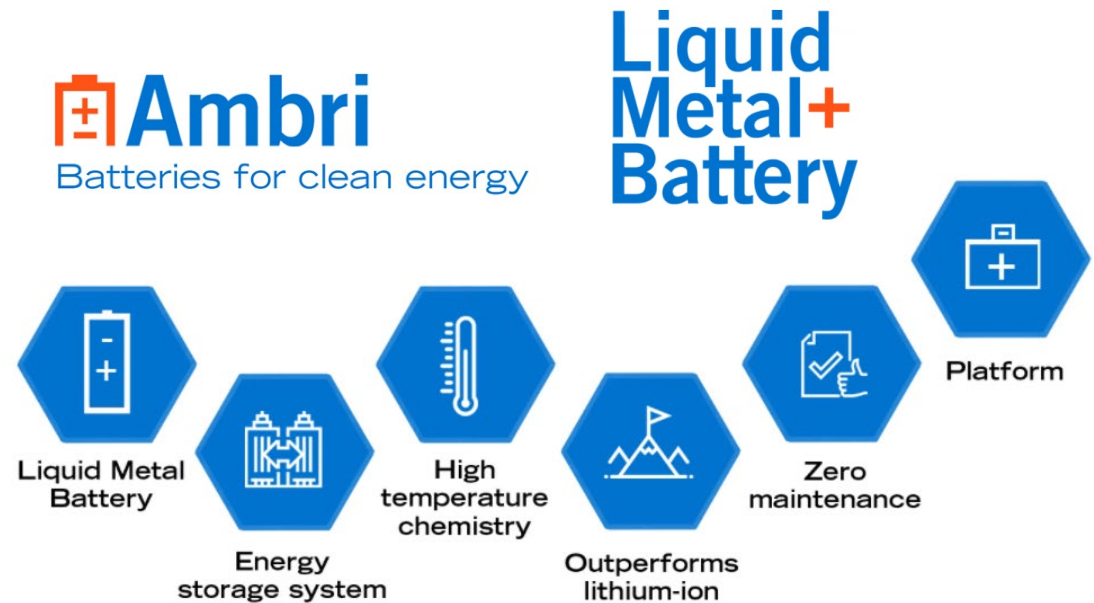

Source: Ambri

Redefining how modern mining companies can be part of climate change solutions



RESTORING AN ABANDONED BROWNFIELDS SITE

ENVIRONMENTAL SOLUTIONS FUNDED THROUGH MINE DEVELOPMENT



Early repair of the largest source of sedimentation



Pick up, reprocess, reuse and safely store 10.5M tons of tailings and spent ore



Re-establish fish migration and provide temporary and permanent river restoration



EXTENSIVE STAKEHOLDER ENGAGEMENT

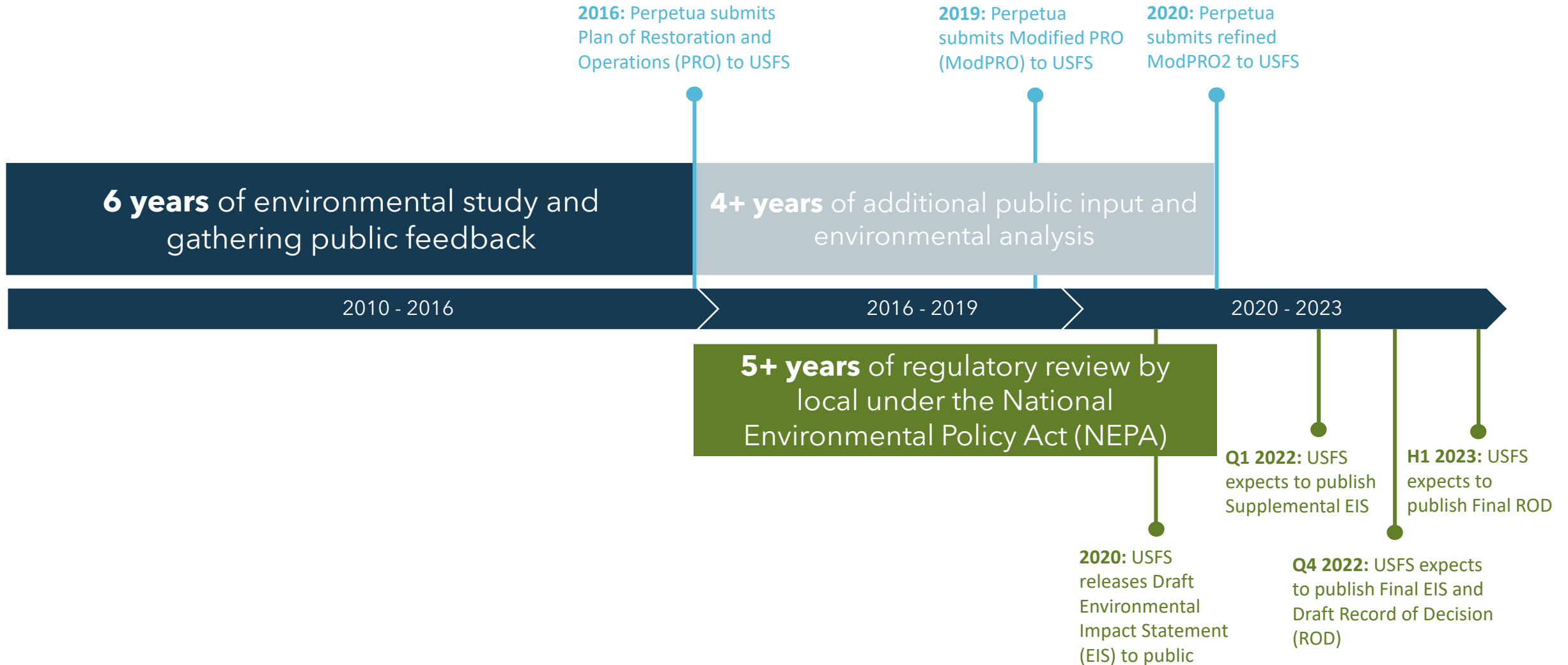

GAINING MOMENTUM WITH NEAR-TERM CATALYSTS



Recent Accomplishments:

- ✓ Draft Environmental Impact Statement and successful comment period (Aug - Oct 2020)
- ✓ Feasibility Study released (Dec 2020)
- ✓ Signed agreement to begin legacy waste cleanup (Jan 2021)
- ✓ Announced name change (Feb 2021)
- ✓ US listing on NASDAQ approved (Feb 2021)
- ✓ Included in the Russell 2000® Index (June 2021)
- ✓ Signed Antimony agreement with Ambri (Aug 2021)
- ✓ Raised \$57.5M in gross proceeds (Aug 2021)

Upcoming Milestones:

- ❑ Inclusion in multiple indices due to Nasdaq listing (2021/22)
- ❑ Supplemental Draft Environmental Impact Statement (Q1 2022)*
- ❑ Final Environmental Impact Statement & Draft Record of Decision (ROD) (Q4 2022)*
- ❑ Final ROD (H1 2023)*
- ❑ Ancillary permits & financing (H2 2023)
- ❑ Construction, begin legacy restoration (2024)
- ❑ Commercial operations, ongoing restoration (2027)

**Indicative permitting schedule based on latest published USFS schedule on July 1, 2021*



VALUATION SET TO RE-RATE ONCE PERMITTED

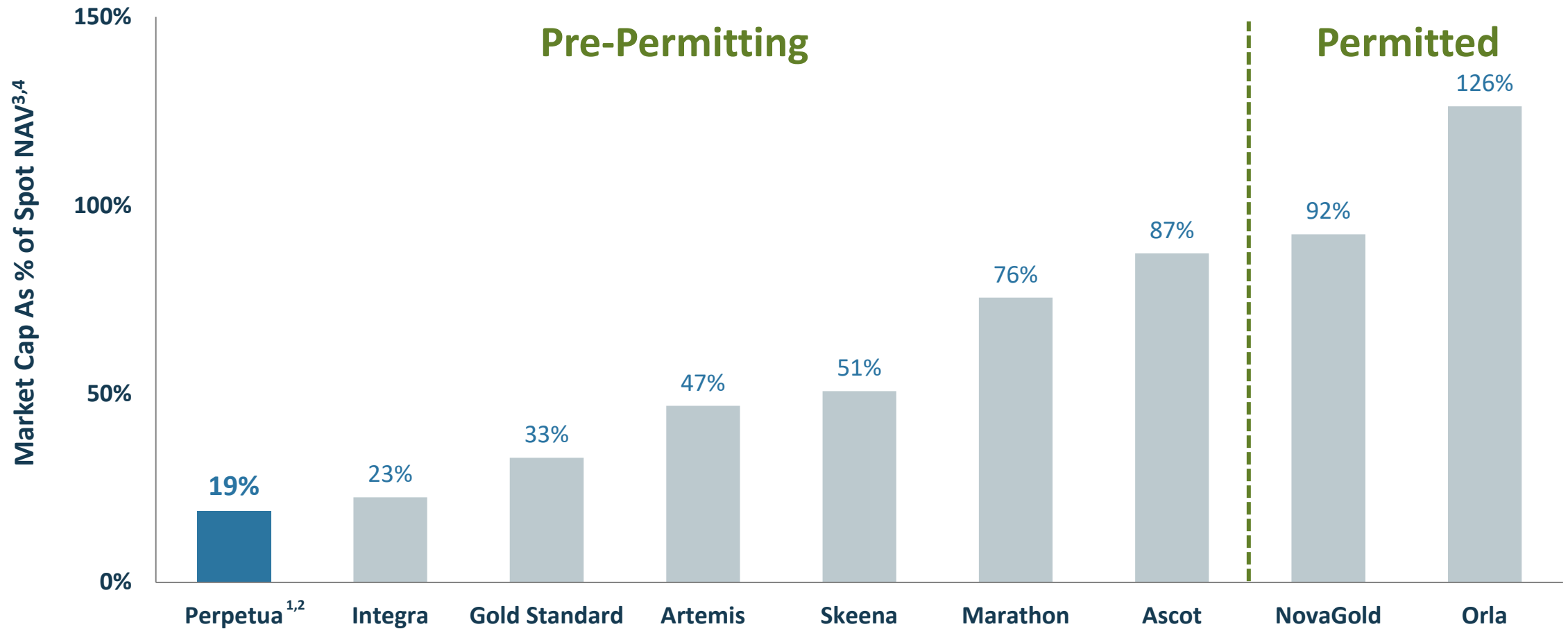

1. Perpetua Resources Market Cap based on Fully Diluted Market Cap as of November 22, 2021.

2. Based on the 2020 Feasibility Study (FS) which is intended to be read as a whole and sections should not be read or relied upon out of context. The information in this presentation is subject to the assumptions, exclusions and qualifications contained in the FS. See "Regulatory Information" at the end of this presentation.

3. NAV's based on after-tax NPV (5% discount rate) based on last available NAV within \$1,850/oz gold price.

4. Based on November 22, 2021 closing stock prices.



A UNIQUE AMERICAN OPPORTUNITY



- ✓ Redeveloping one of **largest, highest grade** and **lowest cost** gold projects in the U.S.*
- ✓ **Superior project economics** with ~15 year reserve life and <3 year payback period*
- ✓ Providing a **U.S critical mineral** to power batteries enabling the **low-carbon energy transition** and for national security
- ✓ Located in **stable mining jurisdiction** with **Idaho community** and **political support**
- ✓ **Sustainable approach** to restoring the environment, improving a legacy, and creating value for all stakeholders
- ✓ **Attractive valuation** with **significant near-term catalysts** and strong balance sheet

**Based on the 2020 Feasibility Study (FS) which is intended to be read as a whole and sections should not be read or relied upon out of context. The information in this presentation is subject to the assumptions, exclusions and qualifications contained in the FS. See "Regulatory Information" at the end of this presentation.*



**Perpetua
Resources**
CORP.

Appendix



SECURING AMERICA'S CRITICAL SUPPLY CHAINS

President Biden's Executive Order and report concludes a secure critical minerals supply chain is essential to our national and economic security

**ANTIMONY IS A KEY MINERAL
IN THREE OF THE FOUR FOCUS AREAS**

- ✓ Semiconductor manufacturing
- ✓ High-capacity batteries
- ✓ Critical minerals
- Pharmaceuticals

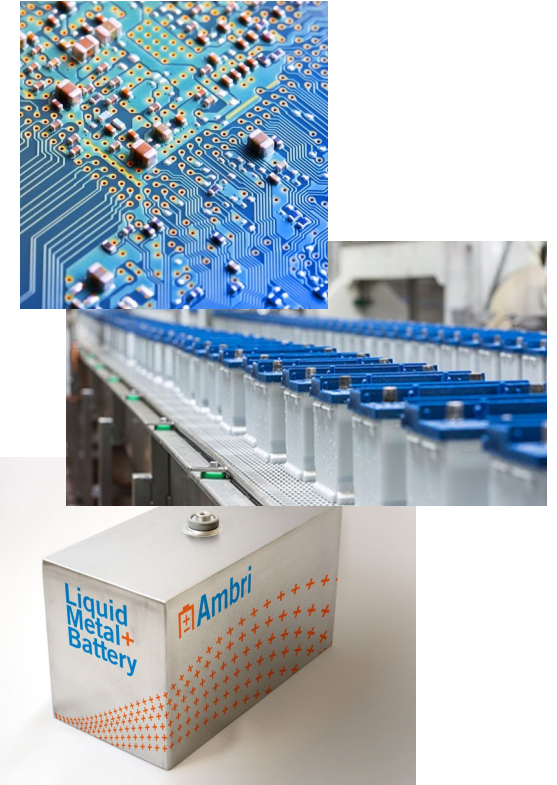

Perpetua Resources can help secure U.S. production of antimony

Source: White House Executive Order February 24, 2021 and Building Resilient Supply Chains, Revitalizing American Manufacturing and Fostering Broad Based Growth 100 day review June 2021



ANTIMONY-BASED LIQUID METAL BATTERIES

ABOUT AMBRI:

- Combining technological innovation with commercial application to store energy longer, in a scalable way that will change the way power grids operate
- Low-cost battery comprised of a liquid calcium alloy anode, a molten salt electrolyte and a cathode comprised of solid particles of antimony
- Ambri recently secured \$144M in capital led by Reliance New Energy Solar (Reliance Industries), Paulson & Co., Bill Gates, Fortistar, Goehring & Rozencwajg and Japan Energy Fund to accelerate growth and build domestic manufacturing facility
- Reliance appointed JV Partner in India as part of broader plans to invest \$10B billion in Green Energy Giga Complex

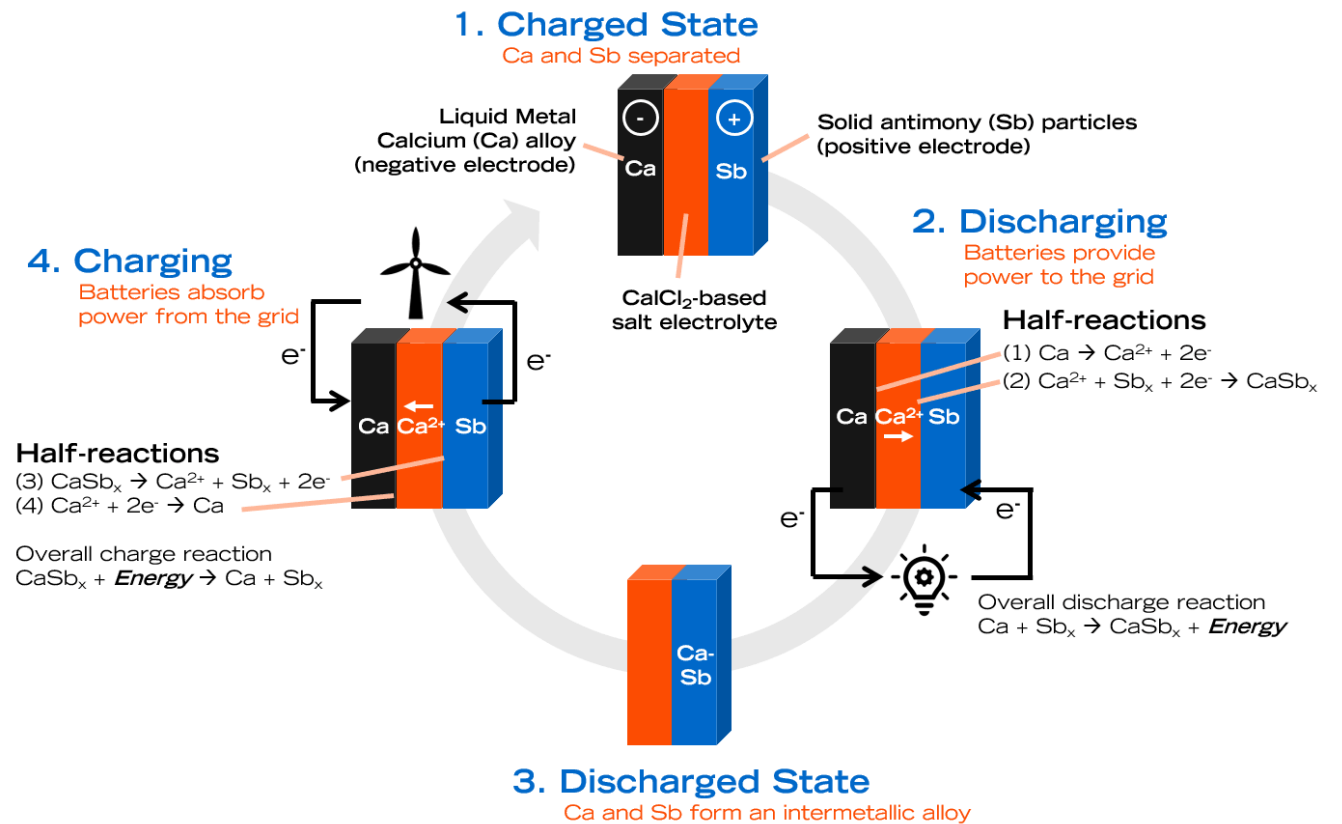

Source: Ambri



VALUATION UPSIDE THROUGH ESG PREMIUM

Trading Comparables – EV / EBITDA

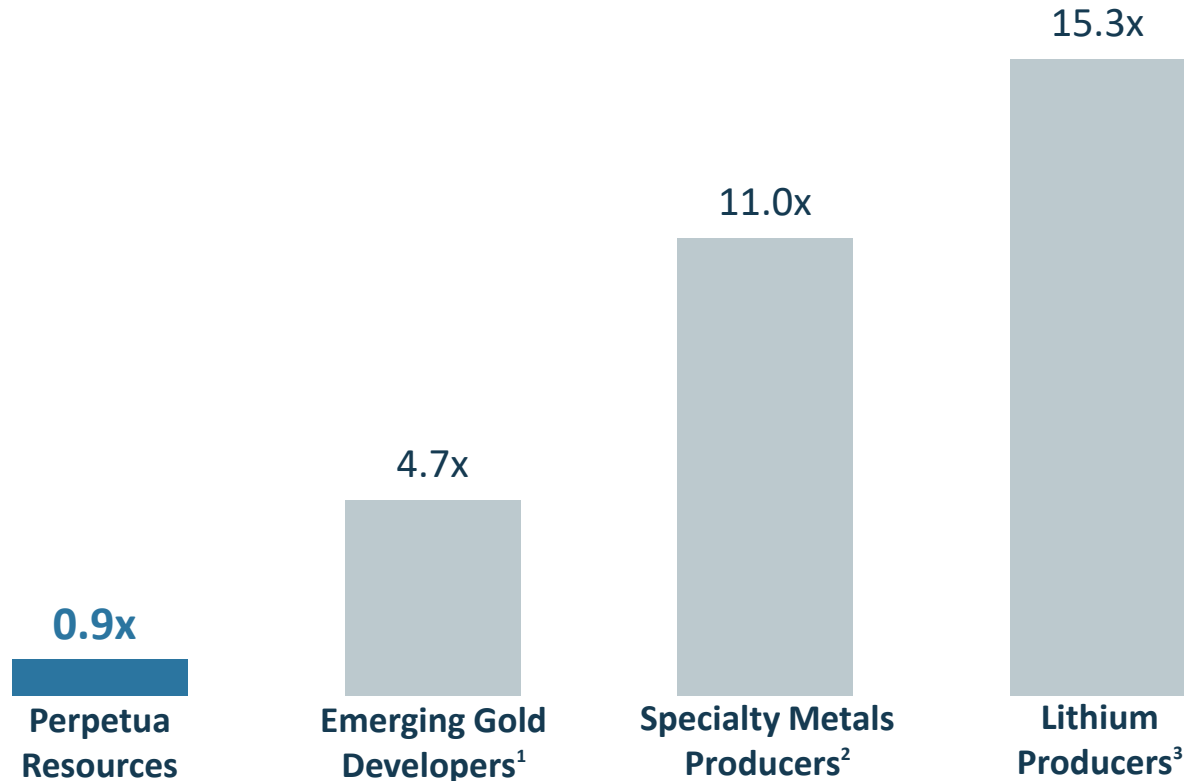

PERPETUA'S UNIQUE VALUE PROPOSITION:

- Strategic partnership with Ambri significantly increases strategic and long-term value
- Antimony by-product to power batteries for long duration, daily cycling energy storage
- Developing a modern mining project to help power a lower carbon future
- Restoring an abandoned brownfields site
- Project will be powered by lowest carbon emissions grid in the nation
- Sustainable approach and strong Environmental, Social and Governance principles built into plans

Source: S&P Capital IQ and latest available company materials as of July 23, 2021

1) Emerging Gold Comps: Orla, NovaGold, Marathon Gold, Skeena Resources, Gold Standard Ventures, Integra Resources

2) Specialty Metals Comps: MP Materials, Piedmont Lithium, Lithium Americas, Largo Resources, Nouveau Monde Graphite, Minerals Technologies, Lynas Rare Earths, Iluka Resources, Neo Performance Materials

3) Lithium Comps: Ganfeng Lithium, Tianqi Lithium Industries, Albemarle Corporation, Sociedad Quimica Y Minera De Chile, Minerals Resources Ltd, Livent, Orocobre, Piedmont Lithium, Lithium Americas Corp.



DIVERSE, EXPERIENCED LEADERSHIP TEAM

EXECUTIVE TEAM



Laurel Sayer
Board Director & CEO



Alan Haslam
VP, Permitting



Mckinsey Lyon
VP, External Affairs



John Meyer
VP, Development



Jessica Largent
VP, Investor Relations & Finance

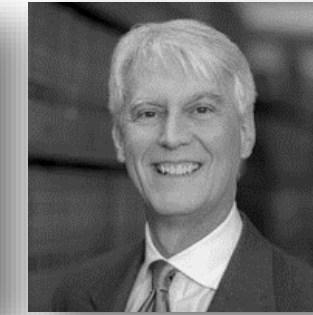

Michael Bogert
General Counsel



Tanya Nelson
VP, Human Resource & Corporate Secretary

CORPORATE BOARD



Marcelo Kim
Chairman
Paulson & Co



Bob Dean
Director
Former Allen Company



David Deisley
Director
Former NovaGold, Goldcorp & Barrick



Jeff Malmen
Director
Idaho Power, Former Chief of Staff Governor Otter



Chris Papagianis
Director
Paulson & Co



Chris Robison
Director
Former Newmont, Rio Tinto Minerals & Kennecott Utah Copper



Alex Sternhell
Director
Sternhell Group, Democrat Dpty. Staff Director US Senate Cm. Banking



IDAHO: A PREMIER MINING JURISDICTION

- **Top 10** Mining Jurisdiction in the World*
- Well-defined Permitting Process
- Substantial **Community and Political Support**
- **Low** Geopolitical Risk
- Significant Investment by Senior Mining Companies: Barrick, Kinross, Yamana and Agnico Eagle

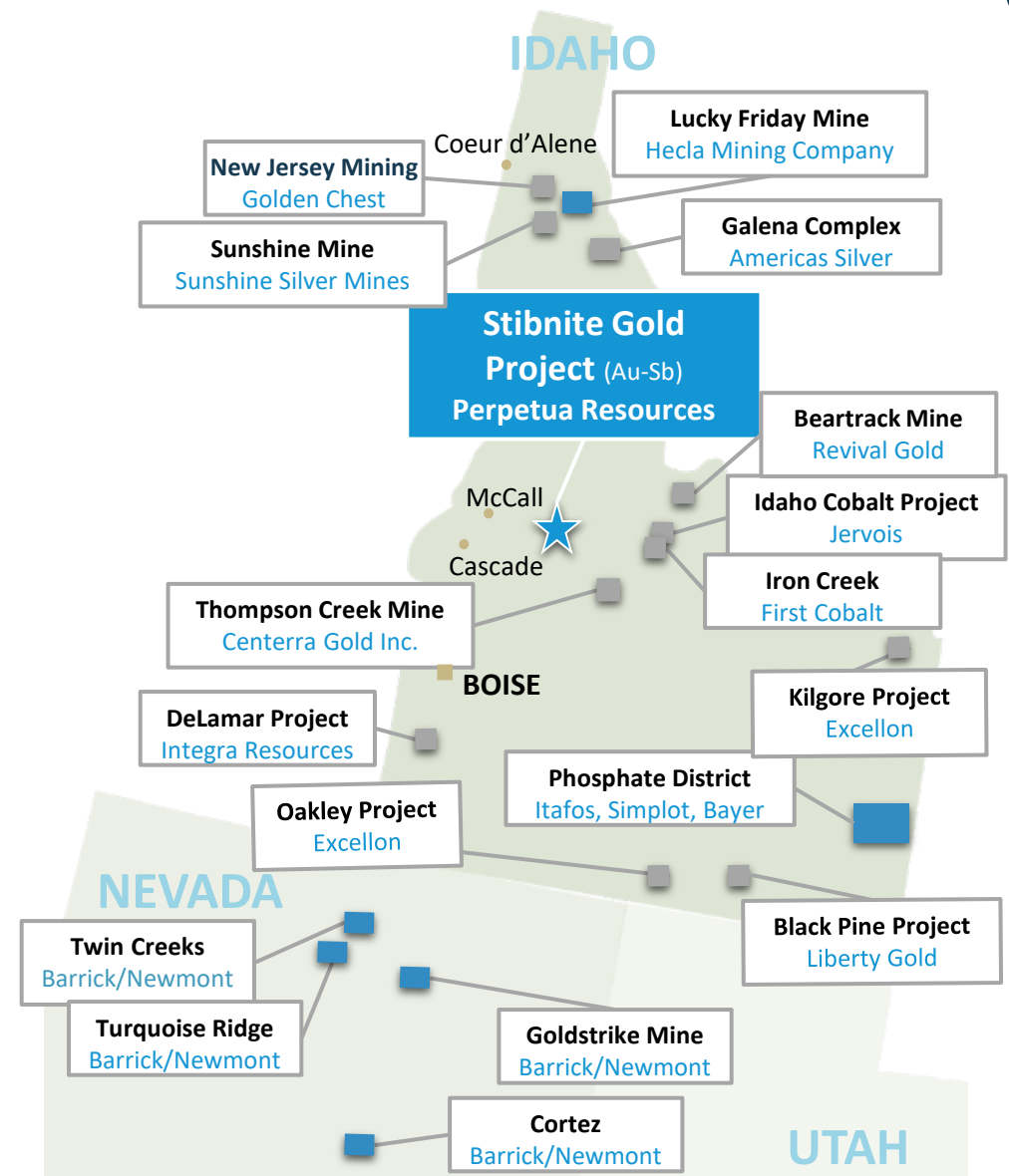

* Source: Fraser institute Survey 2020



CHANGING THE FACE OF MINING

50%
of senior staff
are female



Cindy Kneen, Camp Supervisor

2020
Laurel Sayer named CEO
of Perpetua Resources
Corp & Perpetua
Resources Idaho



Laurel Sayer, CEO

40%
of employees are
female



*Belinda Provancher, Community Relations
Manager*

66%
of Perpetua Resources Idaho, Inc
board members
are female



*April Whitney, Perpetua Resources
Idaho Board Member*

Note: Numbers reflect Perpetua Resources Idaho, Inc. staff and board members as of February 2021

STRONG ENVIRONMENTAL, SOCIAL & GOVERNANCE PRINCIPLES BUILT INTO CORE BUSINESS PLANS

- ✓ Adopted ESG policy in 2019
- ✓ Community Agreement signed in 2018
- ✓ Annual Sustainability Reporting
- ✓ 60k+ Trees Planted
- ✓ 104+ Months No Reportable Spills
- ✓ Dark Skies commitments
- ✓ Installed solar power to reduce current reliance on fuel



2021 ESG Commitments

- ✓ Publish sustainability roadmap



IMPROVING A LEGACY

PLAN DESIGNED WITH POST MINING RESTORATION GOALS IN MIND, INCLUDING WILDLIFE, FISHERIES & DISPERSED RECREATION

- Create a self-sustaining natural environment
- Support healthy fish and wildlife population
- Significant concurrent reclamation & restoration
- Revegetation, reforestation & wetland mitigation
- Address historical impacts from legacy mining
- 10+ year post-operations closure period
- 25 years of water treatment estimated

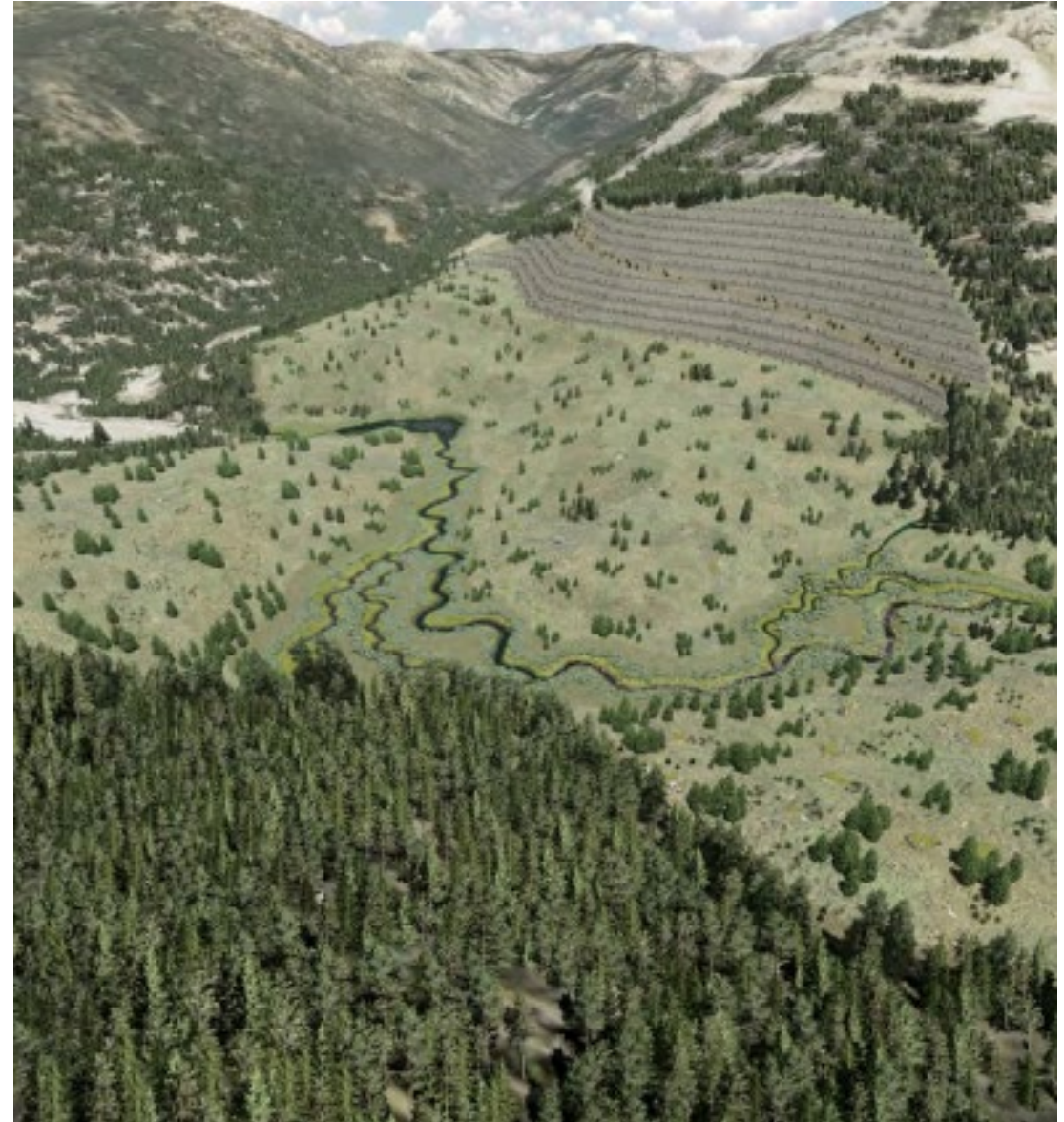

Based on the 2020 Feasibility Study (FS) which is intended to be read as a whole and sections should not be read or relied upon out of context. The information in this presentation is subject to the assumptions, exclusions and qualifications contained in the FS. See "Regulatory Information" at the end of this presentation.



NEPA AT WORK

Public feedback and refinement create the best plan

TRANSPARENCY: 75-Day Public Comment Period

REFINEMENT: Agencies Responding to the Public

Positive vs. Negative Comments

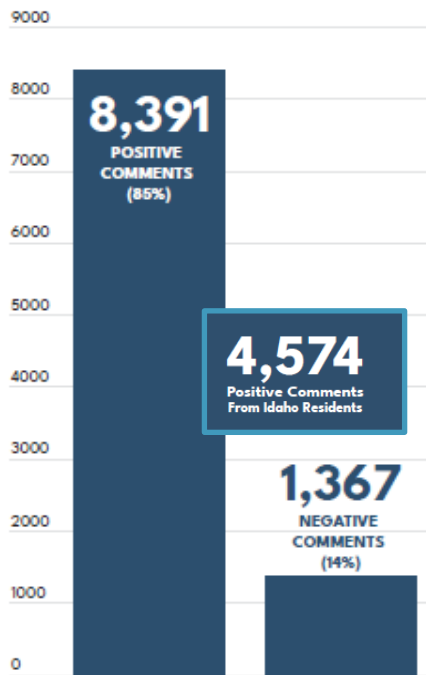

Comments Submitted from Idaho

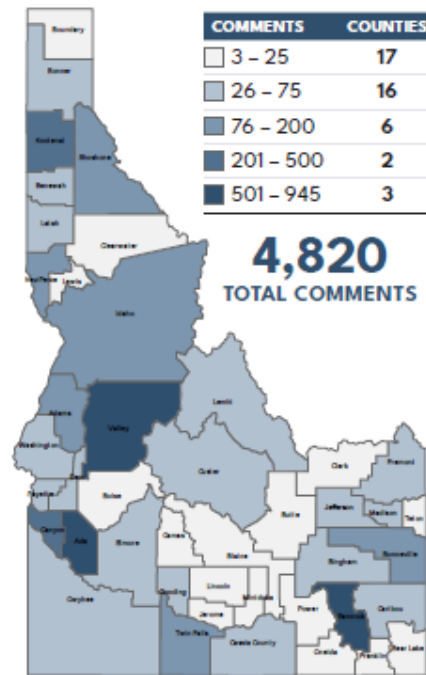

*Numbers are based on individually submitted comments to the U.S. Forest Service.

*Numbers are based on address provided by commenters. Not all commenters provided address information.

The U.S. Forest Service & cooperating agencies will:

- Review all comments
- Respond to the public
- Incorporate feedback into their final analysis
- Identify the Selected Plan based on scientific analysis, public feedback and state and federal requirements.
- Publish a Final Environmental Impact Statement
- Issue a Draft Record of Decision
- Conduct Objection Resolution
- Issue a Final Record of Decision



PERPETUA'S REFINED PROPOSED ACTION

WHAT WE HEARD

✦ **Reduce the project footprint**

✦ **Improve water quality**

✦ **Reduce water temperature**

Based on public and agency feedback on the Draft EIS, Perpetua submitted project refinements to the USFS in December 2020. The improvements create better environmental outcomes and are responsive to public input. The agency has decided to advance the improved project design forward for additional public review.

PROJECT IMPROVEMENTS

10% reduction in total volume mined (44 million tons)

70% reduction in Hangar Flats pit size (the pit can be completely backfilled)

7% reduction in disturbance from open pits (37 acres)

168-acre reduction in disturbance without Fiddle Development Rock Storage Facility

Improved Water Quality through elimination of Fiddle Development Rock Storage Facility

Improved Water Temperature to reach levels closer to baseline.



PERMITTING – NEXT STEPS



EIS: Environmental Impact Statement
DEIS: Draft Environmental Impact Statement
FEIS: Final Environmental Impact Statement

NOA: Notice of Availability
PRO: Plan of Restoration and Operations
ROD: Record of Decision



EXPLORATION UPSIDE*

EXPANSIVE LAND PACKAGE

EXISTING DEPOSITS:

- Northeast of Yellow Pine Deposit
- Below Hangar Flats pit & Old Defense Minerals Exploration Act (DMEA) working area
- West End along strike and at depth

PRIORITY EXPLORATION TARGETS:

- High grade targets (Garnet, Scout, Upper Midnight)
- Bulk tonnage targets (Cinnamid-Ridgetop, Saddle-Fern, Rabbit)
- Undefined airborne targets (Mule, Salt & Pepper, Blow-out)

PIPELINE OF ANTIMONY-RICH TARGETS

* Some of the prospects are conceptual in nature, there has been insufficient exploration to define a mineral resource and it is uncertain if further exploration will result in the target being delineated as a mineral resource.

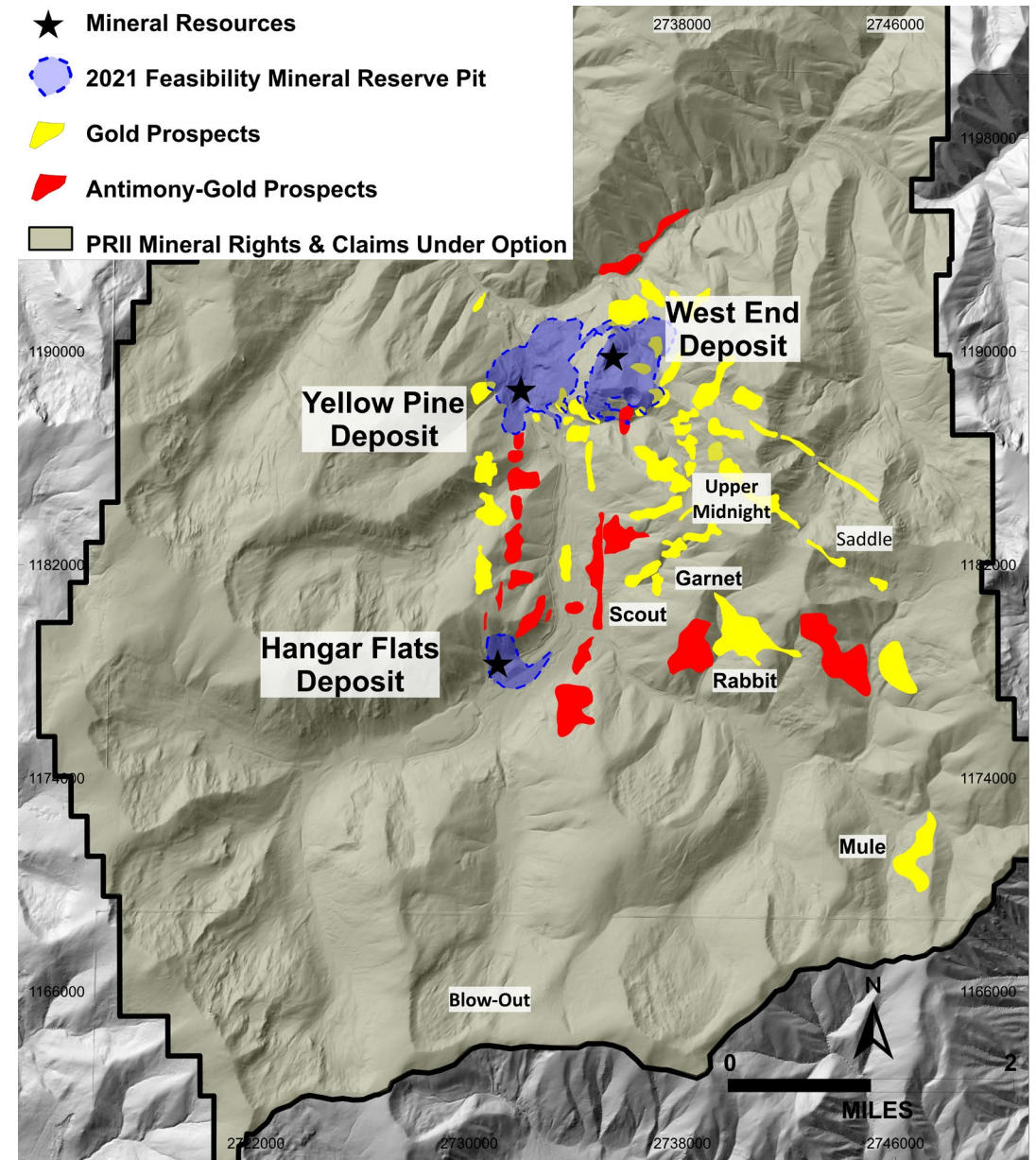



MINERAL RESOURCES & RESERVES¹

Proven & Probable Mineral Reserves:

4.8 Mozs Gold @1.43 g/t

148 M lbs antimony at 0.06% contained in 104 Mt

Measured & Indicated Mineral Resources:

6.0 Mozs Gold @1.42g/t

206 Mlbs antimony at 0.07% contained in 132 Mt

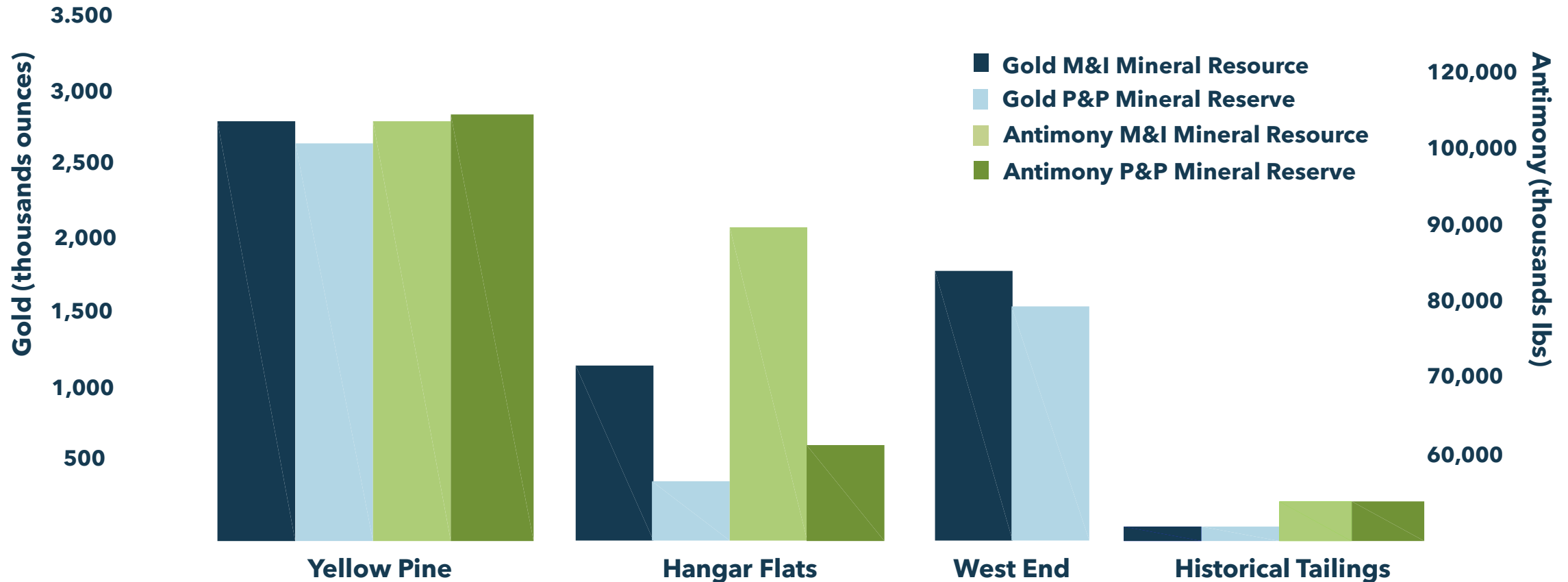

1. Based on the 2020 Feasibility Study (FS) which is intended to be read as a whole and sections should not be read or relied upon out of context. The information in this presentation is subject to the assumptions, exclusions and qualifications contained in the FS. See "Regulatory Information" at the end of this presentation. The Mineral Reserves are contained within the Mineral Resources. Mineral Reserves were calculated using an Au price of \$1600/oz and Sb price of \$3.50/lb and variable cut off grade of 0.39-0.49 g/t Au. Mineral Resources were calculated using a \$1250/oz Au price and sulfide cut off grade of 0.45 g/t Au and oxide COG of 0.4 g/t Au.



FEASIBILITY STUDY - HIGHLIGHTS

Component	Early Production Years 1-4	Life-of-Mine Years 1-15
Total Recovered Gold	1,853 koz	4,238 koz
Total Recovered Antimony	74 Mlbs	115 Mlbs
Average Annual Recovered Gold	463 koz/yr	297 koz/yr
Cash Costs Net of By-Product Credits	\$328/koz	\$538/koz
All-in Sustaining Costs Net of By-Product Credits	\$438/koz	\$636/koz
Initial Capital including Contingency	\$1,263 million	
\$1,600/oz gold - \$20/oz silver - \$3.50/lb antimony		
After-Tax Net Present Value at 5% Discount Rate	\$1,320 million	
Annual Average EBITDA	\$566 million	\$292 million
Annual Average After Tax Free Cash Flow	\$500 million	\$242 million
After Tax Internal Rate of Return	22.3%	
After Tax Payback Period	2.9 years	
\$1,850/oz gold - \$24/oz silver - \$3.50/lb antimony		
After-Tax Net Present Value at 5% Discount Rate	\$1,864 million	
Annual Average EBITDA	\$678 million	\$360 million
Annual Average After Tax Free Cash Flow	\$584 million	\$295 million
After Tax Internal Rate of Return	27.7%	
After Tax Payback Period	2.5 years	

Notes:

1. In this presentation, "M" = million, "k" = thousand, all amounts in US\$, gold and silver reported in troy ounces ("oz")
2. See non-International Financial Reporting Standards ("IFRS") measures listed at the end of this presentation.
3. The FS assumes 100% equity financing of the Project.

Based on the 2020 Feasibility Study (FS) which is intended to be read as a whole and sections should not be read or relied upon out of context. The information in this presentation is subject to the assumptions, exclusions and qualifications contained in the FS. See "Regulatory Information" at the end of this presentation.



FEASIBILITY STUDY - CAPITAL COST SUMMARY

Area	Detail	Initial CAPEX (M \$)	Sustaining CAPEX (M \$)	Closure CAPEX (M \$) ⁽²⁾	Total CAPEX (M \$)
Direct Costs	Mine Costs ⁽¹⁾	84	119	-	203
	Processing Plant	433	49	-	483
	On-Site Infrastructure	191	84	-	275
	Off-Site Infrastructure	116	-	-	116
Indirect Costs		233	-	-	233
Owner's Costs		38	-	-	38
Offsite Environmental Mitigation Costs		14	-	-	14
Onsite Mitigation, Monitoring and Closure Costs ⁽²⁾		3	23	98	125
Total CAPEX without Contingency⁽³⁾		1,113	275	98	1,487
Contingency		150	20	1	171
Total CAPEX with Contingency⁽³⁾		1,263	296	99	1,658

Notes:

1. Initial mining CAPEX includes environmental remediation costs.
2. Closure and mitigation assume self-performed costs, which will differ for those assumed for financial assurance calculations required by regulators. Costs include stream and wetland restoration and reclamation costs.
3. Numbers have been rounded and may not sum correctly.

Based on the 2020 Feasibility Study (FS) which is intended to be read as a whole and sections should not be read or relied upon out of context. The information in this presentation is subject to the assumptions, exclusions and qualifications contained in the FS. See "Regulatory Information" at the end of this presentation.



FEASIBILITY STUDY - OPERATING COST SUMMARY

Total Production Cost Item	Years 1-4		Life of Mine	
	(\$/t milled)	(\$/oz Au)	(\$/t milled)	(\$/oz Au)
Mining	9.71	156	8.22	205
Processing	13.13	211	12.76	318
G&A (including Water Treatment)	3.54	57	3.43	85
Cash Costs Before By-Product Credits	26.38	424	24.41	608
By-Product Credits	(5.99)	(96)	(2.81)	(70)
Cash Costs After of By-Product Credits	20.40	328	21.60	538
Royalties	1.69	27	1.09	27
Refining and Transportation	0.46	7	0.24	6
Total Cash Costs	22.54	362	22.94	571
Sustaining CAPEX	4.64	75	2.83	70
All-In Sustaining Costs	27.23	438	25.54	636
Reclamation and Closure ⁽¹⁾	-	-	0.95	24
Initial (non-sustaining) CAPEX ⁽²⁾	-	-	11.65	290
All-In Costs	-	-	38.14	950

Notes:

1. Defined as non-sustaining reclamation and closure costs in the post-operations period.
2. Initial Capital includes capitalized preproduction.

Based on the 2020 Feasibility Study (FS) which is intended to be read as a whole and sections should not be read or relied upon out of context. The information in this presentation is subject to the assumptions, exclusions and qualifications contained in the FS. See "Regulatory Information" at the end of this presentation.



ANNUAL AFTER-TAX CASH FLOW (@ \$1,850 GOLD PRICE)¹

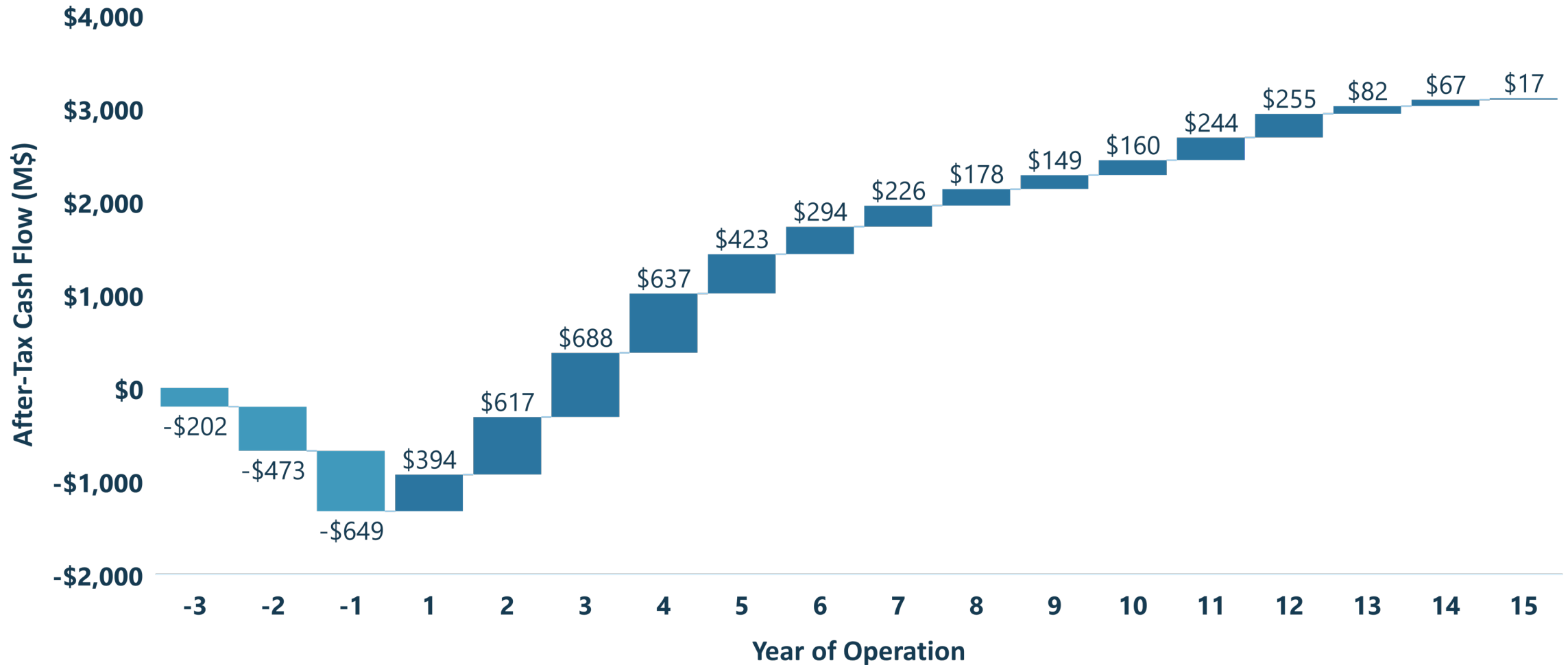

1. Based on the 2020 Feasibility Study (FS) which is intended to be read as a whole and sections should not be read or relied upon out of context. The information in this presentation is subject to the assumptions, exclusions and qualifications contained in the FS. See "Regulatory Information" at the end of this presentation.



STRONG AND SUPPORTIVE SHAREHOLDER BASE

SHAREHOLDERS**

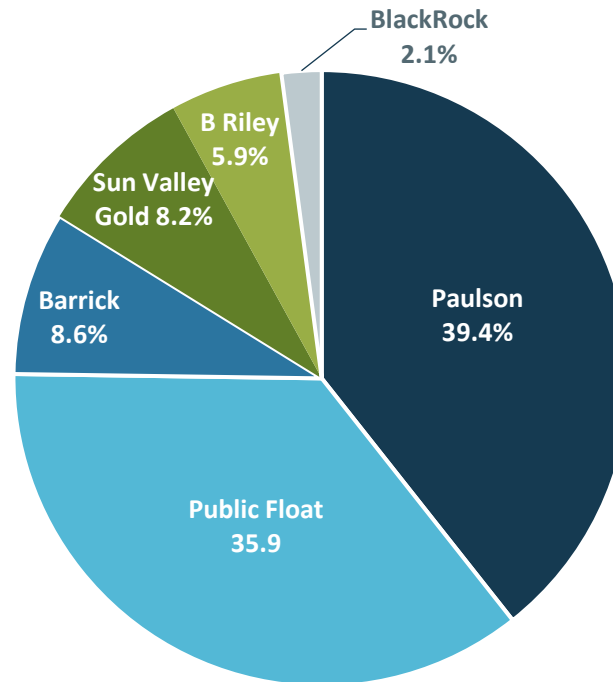

CAPITAL STRUCTURE*

- ❖ Issued & Outstanding 62.94 Million
- ❖ Options 2.57 Million
- ❖ Warrants 0.20 Million
- ❖ Fully Diluted 65.71 Million
- ❖ Estimated Cash Balance ~\$56 Million

RESEARCH COVERAGE

- ❖ B. Riley Financial – Lucas Pipes
- ❖ H.C. Wainwright – Heiko Ihle
- ❖ Cantor Fitzgerald – Mike Kozak
- ❖ Hallgarten – Christopher Ecclestone



**Perpetua
Resources**

*Capital structure estimate as of September 30, 2021

**Based on most recent shareholder filings



REGULATORY INFORMATION

The FS was compiled by M3 Engineering & Technology Corporation (“M3”) in accordance with National Instrument 43-101 – *Standards of Disclosure for Mineral Projects* (“NI 43-101”) under the direction of independent qualified persons (as defined in NI 43-101) (“Independent QPs”). Independent QPs for the FS include: Richard Zimmerman, SME-RM (onsite and offsite infrastructure, cost estimating and financial modeling) and Art Ibrado, P.E. (mineral processing) with M3; Garth Kirkham, P.Geo. (mineral resources) with Kirkham Geosystems Ltd.; Christopher Martin, C.Eng. (metallurgy) with Blue Coast Metallurgy Ltd.; Grenvil Dunn, C.Eng. (hydrometallurgy) with Hydromet WA (Pty) Ltd.; Chris Roos, P.E. (mineral reserves) and Scott Rosenthal P.E. (mine planning) with Value Consulting, Inc.; and Peter Kowalewski, P.E. (tailings storage facility and closure) with Tierra Group International, Ltd.

The material scientific and technical information in respect of the Project in this presentation, unless otherwise indicated, is based upon information contained in the FS. Readers are encouraged to read the FS, which is available under the Company's profile on SEDAR, for detailed information concerning the Project. All disclosure contained in this presentation regarding the mineral reserves and mineral resource estimates and economic analysis on the property is fully qualified by the full disclosure contained in the FS.

Information of a scientific or technical nature in this presentation has been approved by Austin Zinsser, SME-RM, Sr. Resource Geologist for Perpetua Resources Idaho, Inc. and a qualified person (as defined in Ni 43-101).

All mineral resources have been estimated in accordance with CIM definitions. Mineral resources are reported in relation to a conceptual pit shell to demonstrate potential for economic viability, as required under NI 43-101; mineralization lying outside of these pit shells is not reported as a mineral resource. Mineral resources are not mineral reserves and do not have demonstrated economic viability. Mineral resource estimates include inferred mineral resources that are considered too speculative geologically to have economic considerations applied to them that would enable them to be categorized as mineral reserves. It is reasonably expected that the majority of inferred mineral resources could be upgraded to indicated mineral resources.

The mineral resources and mineral reserves at the Stibnite Gold Project are contained within areas that have seen historic disturbance resulting from prior mining activities. In order for the Company to advance its interests at the Stibnite Gold Project, the Project will be subject to a number of federal, state and local laws and regulations and will require permits to conduct its activities.

NON-IFRS REPORTING MEASURES

"Cash Costs", "All-in Sustaining Costs" and "Total costs" are not performance measures reported in accordance with International Financial Reporting Standards ("IFRS"). These performance measures are included because the statistics are key performance measures that management uses to monitor performance. Management uses these statistics to assess how the Project ranks against its peer projects and to assess the overall effectiveness and efficiency of the contemplated mining operations. These performance measures do not have a meaning within IFRS and, therefore, amounts presented may not be comparable to similar data presented by other mining companies. These performance measures should not be considered in isolation as a substitute for measures of performance reported in accordance with IFRS.